



# Transmission of Light in Fiber for Optical Communication

Mrs. Gwen MW Kao  
on behalf of  
Professor Charles K Kao  
Nobel Laureate in Physics 2009

8 December 2009  
Aula Magna  
Stockholm University



**Sand from centuries past;  
Send future voices fast.**



# Early years



# STL building in 1960's



Now called Kao-Hockham Building in Harlow, Essex, UK



# Low-loss corrugated circular waveguide

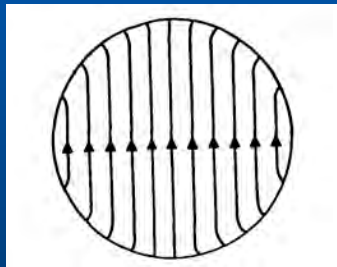
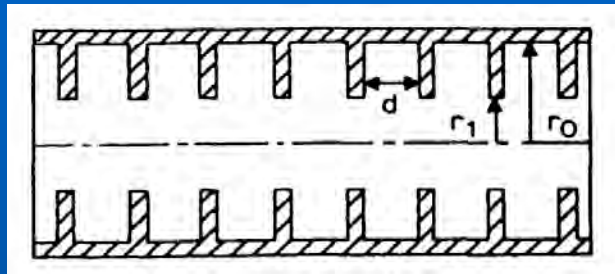

HE11 Mode

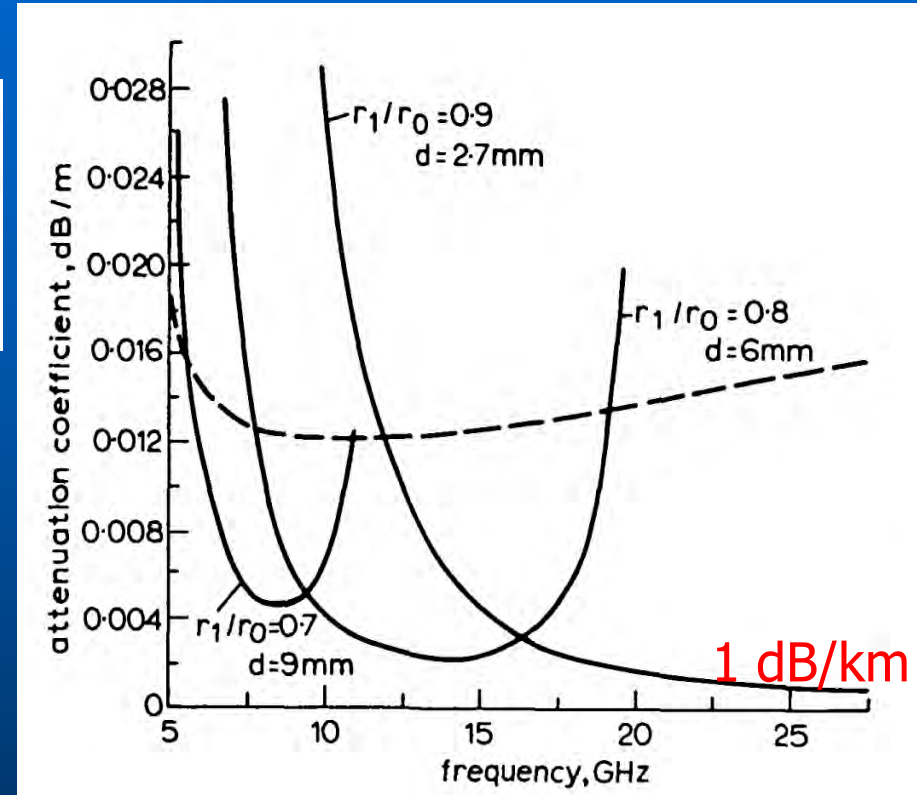

P.J.B. Clarricoat & P.K. Saha, "Attenuation in Corrugated Circular Waveguide," *Elect. Lett.*, Vol.12, pp.370-2, 1970.





# Young Kao at workplace

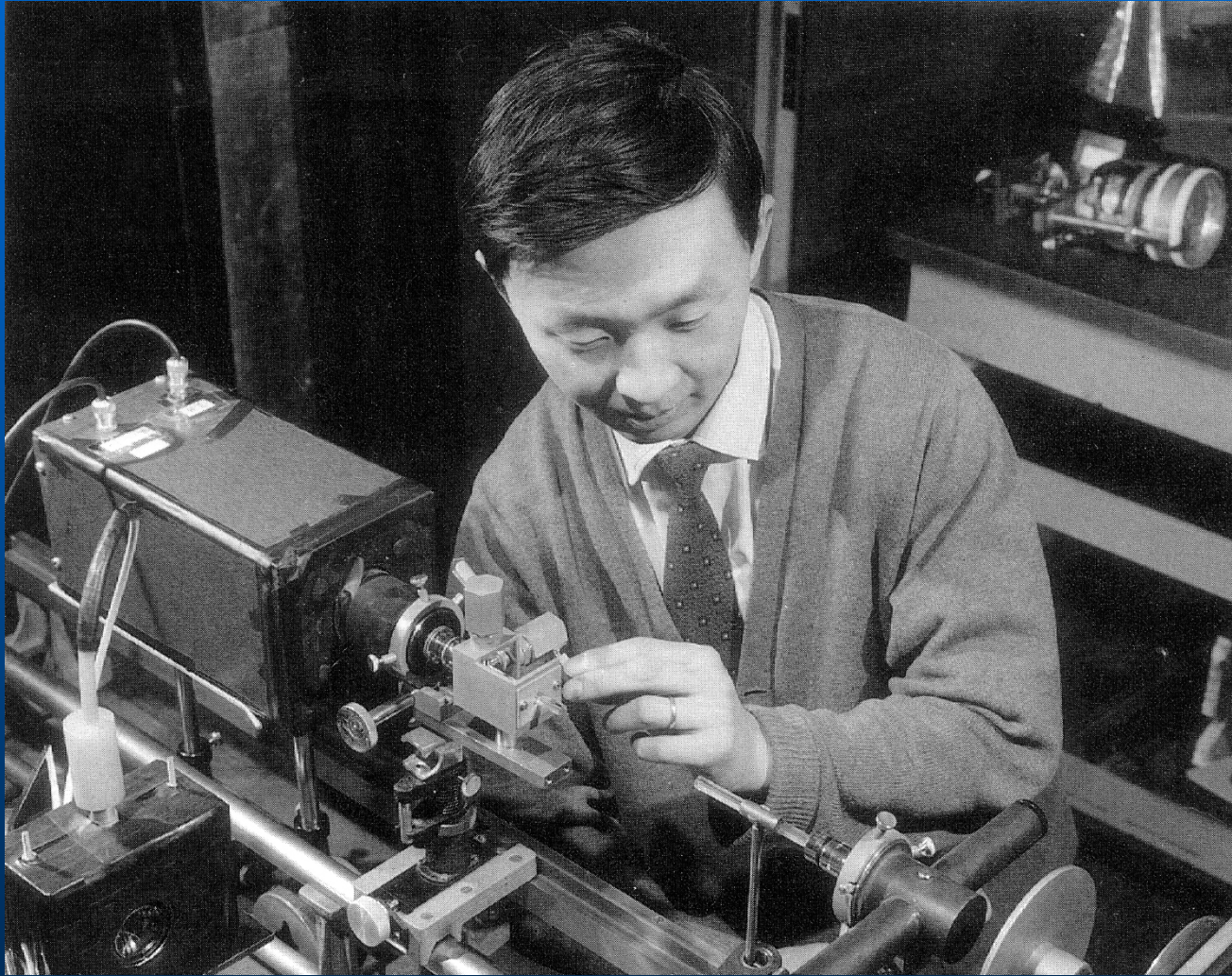

# Laser invented

**1917:** Einstein postulated stimulated emission

**1953:** Townes, Gordon, and Zeiger demonstrated Maser

**1958:** Townes and Schawlow invented Laser



**Charles H. Townes**



**Arthur L. Schawlow**

<http://www.bell-labs.com/history/laser/invention/>



# A race between mm waveguide and optical communication

Millimeter Waveguide	Optical Communication
Mature technology	Unknown technology
Ready for deployment	Promising but nothing is sure
Expensive	Potentially low cost
Phone monopoly can afford the cost	Who are the investors?
Moderate capacity improvement	100,000X better

Odds favored the matured millimeter wave technology





# Two key questions raised by Prof Kao

- 1. Is Ruby laser a suitable source for optical communication?*
- 2. What material has sufficiently high transparency at such wavelengths?*

Difficult problems but fortune favors the brave!



# Free space optical communications

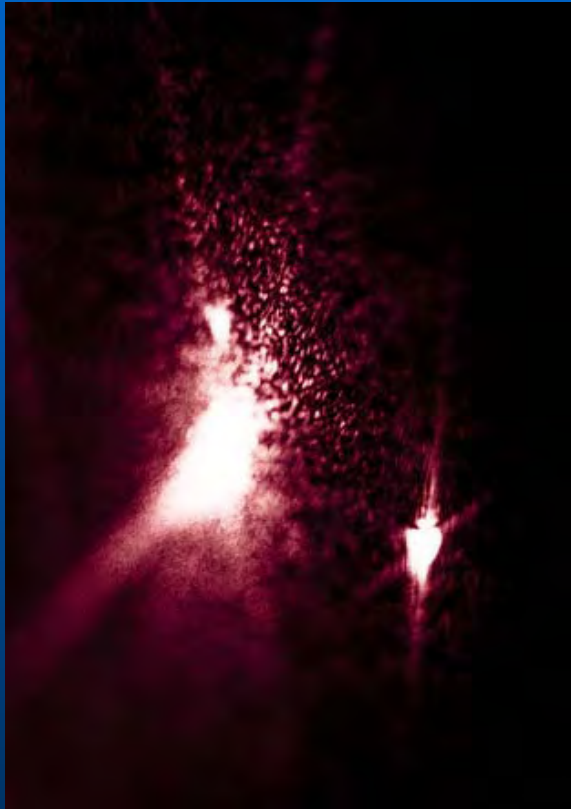

Laser flickers in free space!

A waveguide needed.



[http://en.wikipedia.org/wiki/Speckle\\_pattern](http://en.wikipedia.org/wiki/Speckle_pattern)



# Con-focal lens system

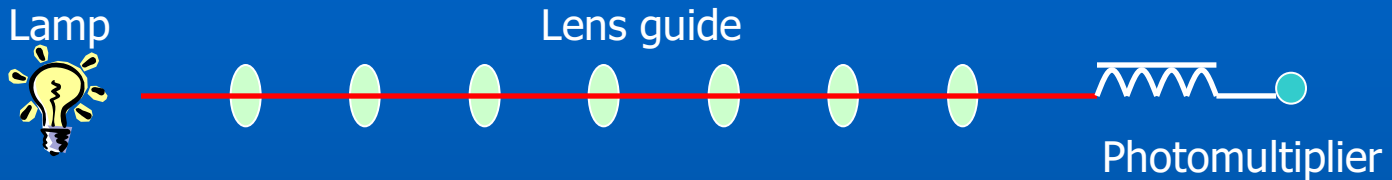

Alignment of the lenses is critical!

Thermal gradient can cause beam to shift by many cm

O.E. DeLange, "Losses suffered by coherent light redirected and refocused many times in an enclosed medium," *Bell Sys. Tech. J.*, Vol.**44**, p. 283, 1965.

D. Gloge, "Experiments with an underground lens waveguide," *Bell Sys. Tech. J.*, Vol.**46**, 721, 1967.





# Gas lens system

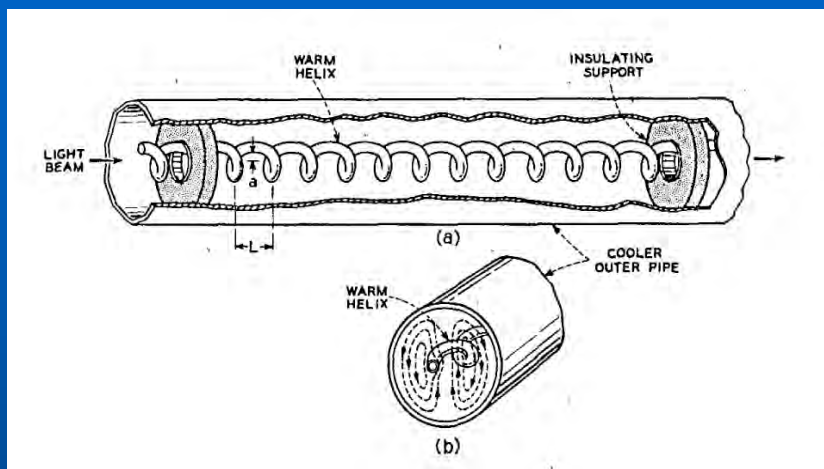

Difficult to insulate!

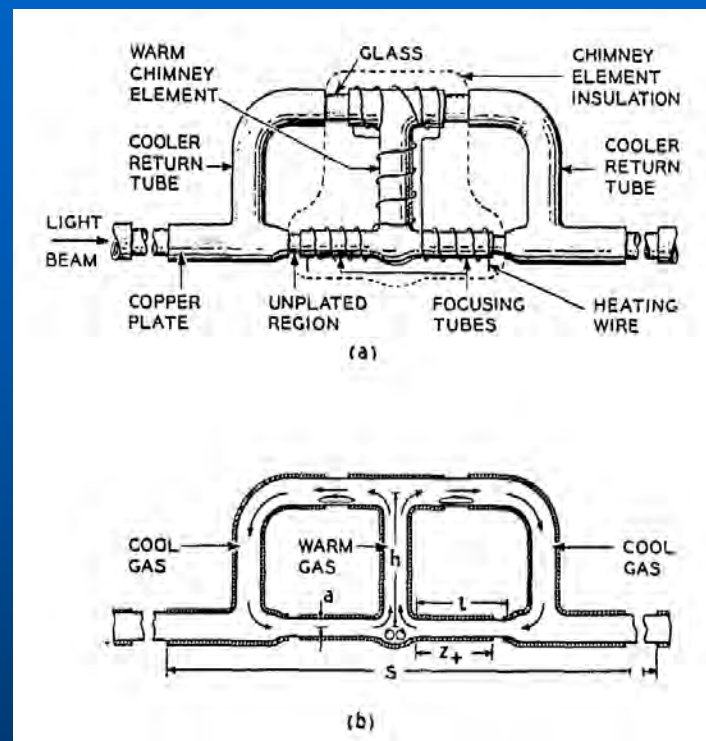

D.W. Berreman, "Convective Gas Light Guides or Lens Trains for Optical Beam Transmission," *J. Opt. Soc. Of Am.*, Vol.55, pp.239-247, 1965.



# Hollow metallic and dielectric waveguides

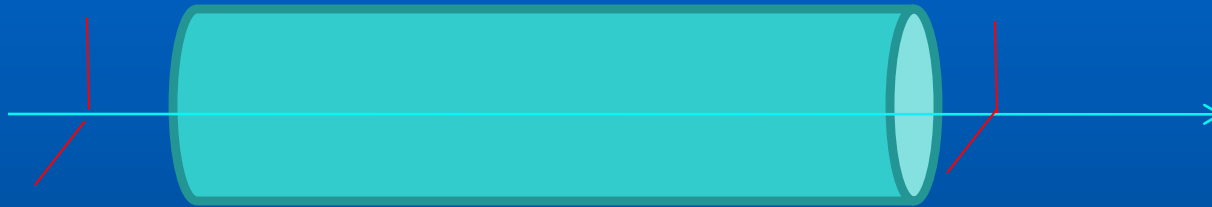

Large bending loss and expensive

E.A.J. Marcatili and R.A. Schmelzter, "Hollow metallic and dielectric Waveguides for long distance optical transmission and lasers," Bell Sys. Tech. J. Vol.43, p.1783, 1964.



# Thin film waveguide

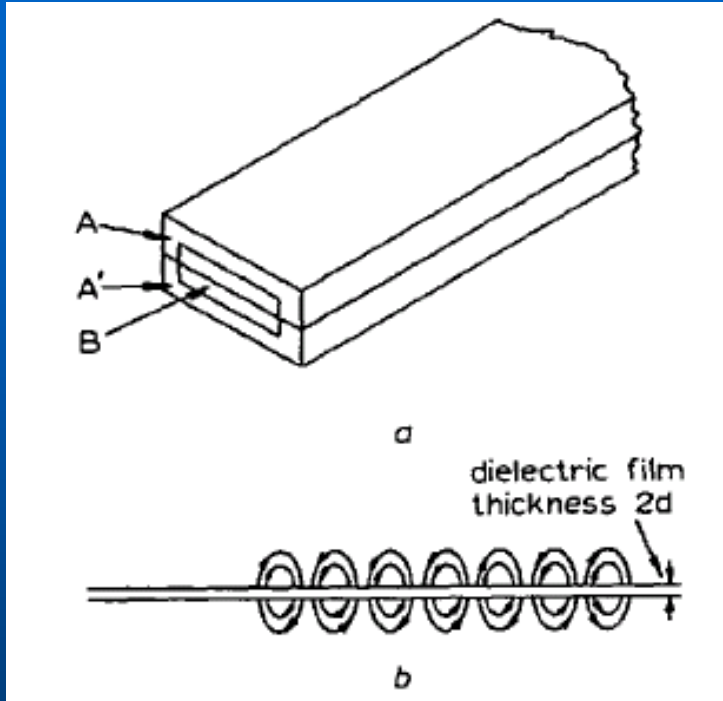

a. A thin film waveguide surrounded by supporting material

b. Field structure of guided wave

Confinement not strong enough and light escapes in bends

A.E. Karbowiak, "New type of waveguide for light and infrared waves," *Elect. Lett.*, Vol. 1, pp.47-8, April 1965.





# Prof Kao's team pursued dielectric silica waveguide approach

- Problems to be solved
  - **Loss reduction** in dielectric waveguide materials
  - **Physical and waveguide limitations** for glass fiber
  - **Better light source** needs
    - a semiconductor laser in the near infrared
    - emission characteristics matching the diameter of a single mode fiber
    - durability and can work at room temperatures
  - **Measurement of the optical loss** of highly transparent materials



# Optical loss of transparent materials

- **Intrinsic loss** in the materials itself (infrared absorption)
- **Extrinsic loss** due to impurity ions
- **Rayleigh scattering loss** due to structure non-uniformity

Is silica glass a suitable material ?  
But all experts said its loss is too high!



# What needs to be done

- *Impurities*, particularly transition elements such as iron, copper, manganese, **have to be reduced** to parts per million or even parts per billion.
- *High temperature glasses* are frozen rapidly and are more homogeneous, leading to a lower scattering loss.





# The 1966 paper

## Dielectric-fibre surface waveguides for optical frequencies

K. C. Kao, B.Sc.(Eng.), Ph.D., A.M.I.E.E., and G. A. Hockham, B.Sc.(Eng.), Graduate I.E.E.

### Synopsis

A dielectric fibre with a refractive index higher than its surrounding region is a form of dielectric waveguide which represents a possible medium for the guided transmission of energy at optical frequencies. The particular type of dielectric-fibre waveguide discussed is one with a circular cross-section. The choice of the mode of propagation for a fibre waveguide used for communication purposes is governed by consideration of loss characteristics and information capacity. Dielectric loss, bending loss and radiation loss are discussed, and mode stability, dispersion and power handling are examined with respect to information capacity. Physical-realisation aspects are also discussed. Experimental investigations at both optical and microwave wavelengths are included.

*PROC. IEE, Vol. 113, No. 7, JULY 1966*

## The birthday of optical fiber communication



# Waveguide design

- The following form of optical waveguide has a **larger information capacity** and possible **advantages in basic material cost**.
  - A fiber of glassy material in a cladded structure
  - Core diameter  $\sim \lambda_0$
  - Overall diameter  $\sim 100 \lambda_0$
  - Refractive index of the core  $\sim 1\%$  higher than the cladding.
  - Single  $HE_{11}$ ,  $E_0$  or  $H_0$  mode operation
  - Information capacity in excess of 1 Gc/s. ...



# Detailed analysis of fiber losses

Intrinsic loss can be as low as 1 dB/km!

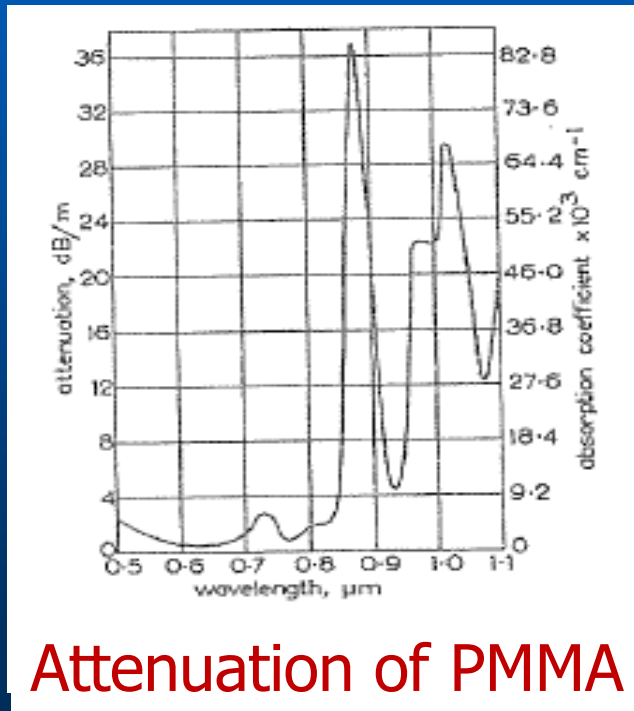

Attenuation of PMMA

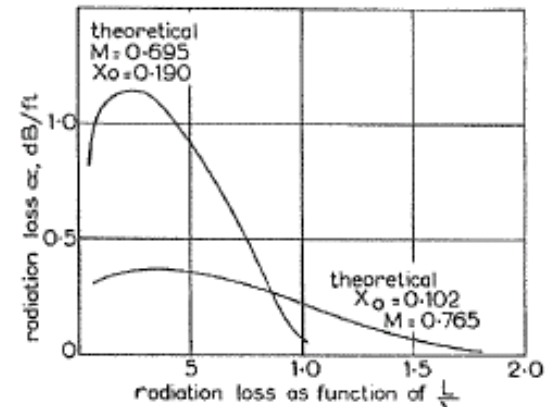

Radiation loss

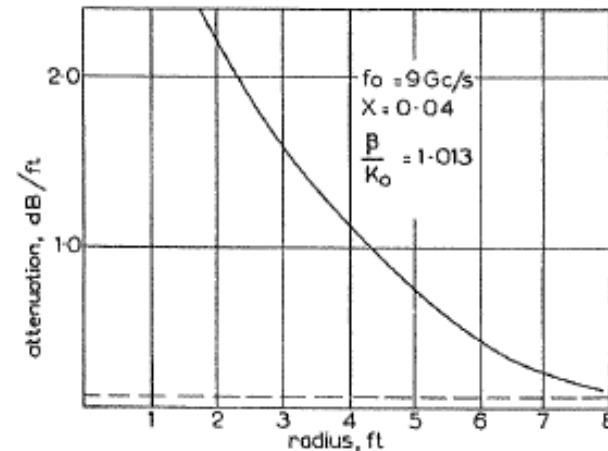

Bending loss





# Main points of the 1966 paper

- Loss can be reduced if the **mode** is properly chosen;
- Proposal for a fiber surrounded by a **cladding** of lower index - became the standard technology;
- Negligible energy loss due to **fiber bends** larger than 1 mm;
- Estimation of fiber losses for **non-uniform** cross-section;
- Analysis of the **properties** of a single mode fiber;
- Bandwidth limited by **dispersion**.



# Conclusions of the 1966 paper

- The realization of a successful fiber waveguide depends, at present, on the availability of suitable low-loss dielectric material. **The crucial material problem appears to be one which is difficult but not impossible.**
- Certainly, the required loss figure of around **20 dB/km** is much higher than the lower limit of loss figure imposed by fundamental mechanisms.



# In hindsight

In hindsight, the revolutionary conclusion was too conservative.

To date, **loss** is **1/100** as predicted, **bandwidth** is **10,000** times predicted!



# Prof Kao travelled to convince the world



At an early OFC meeting

Science Museum  
South Kensington, London





# Measurement problems

- Two formidable challenges
  - A sample size only  $\sim 20$  cm – difficult to measure low-loss
  - End surface reflection loss could be an order of magnitude higher than the actual loss



# Measurement of fiber loss

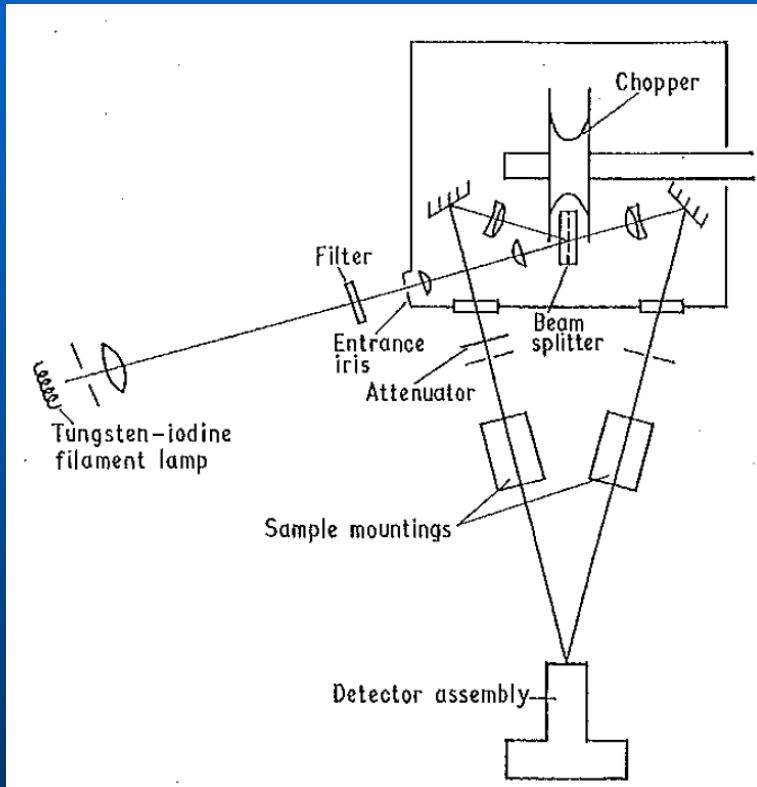

- Loss too low to measure
- Built a double beam spectrophotometer to improve sensitivity by 10X!
- The surface effect was characterized by a homemade *ellipsometer*.

## Double Beam Spectrophotometer

M.W. Jones and K.C. Kao, "Spectrophotometric studies of ultra low loss optical glasses II" J. Sci. Instrum. (J. Phys. E), Vol.2, pp. 331-5, 1969.



# Demonstration of silica glass as waveguide material

- An Infrasil sample from Schott Glass showed an attenuation **as low as 5 dB/km** at a window around 850 nm!
- **850 nm - GaAs laser emission region.**

M.W. Jones and K.C. Kao,  
"Spectrophotometric studies  
of ultra low loss optical  
glasses II" J. Sci. Instrum.  
(J. Phys. E), Vol.2, pp. 331-  
5, 1969.

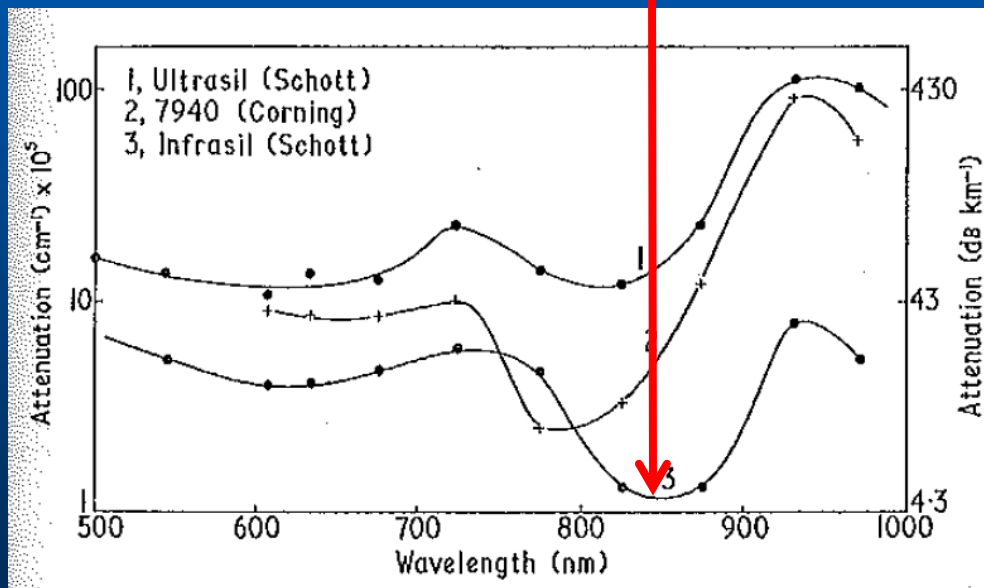

# The race to develop the first low-loss optical fiber

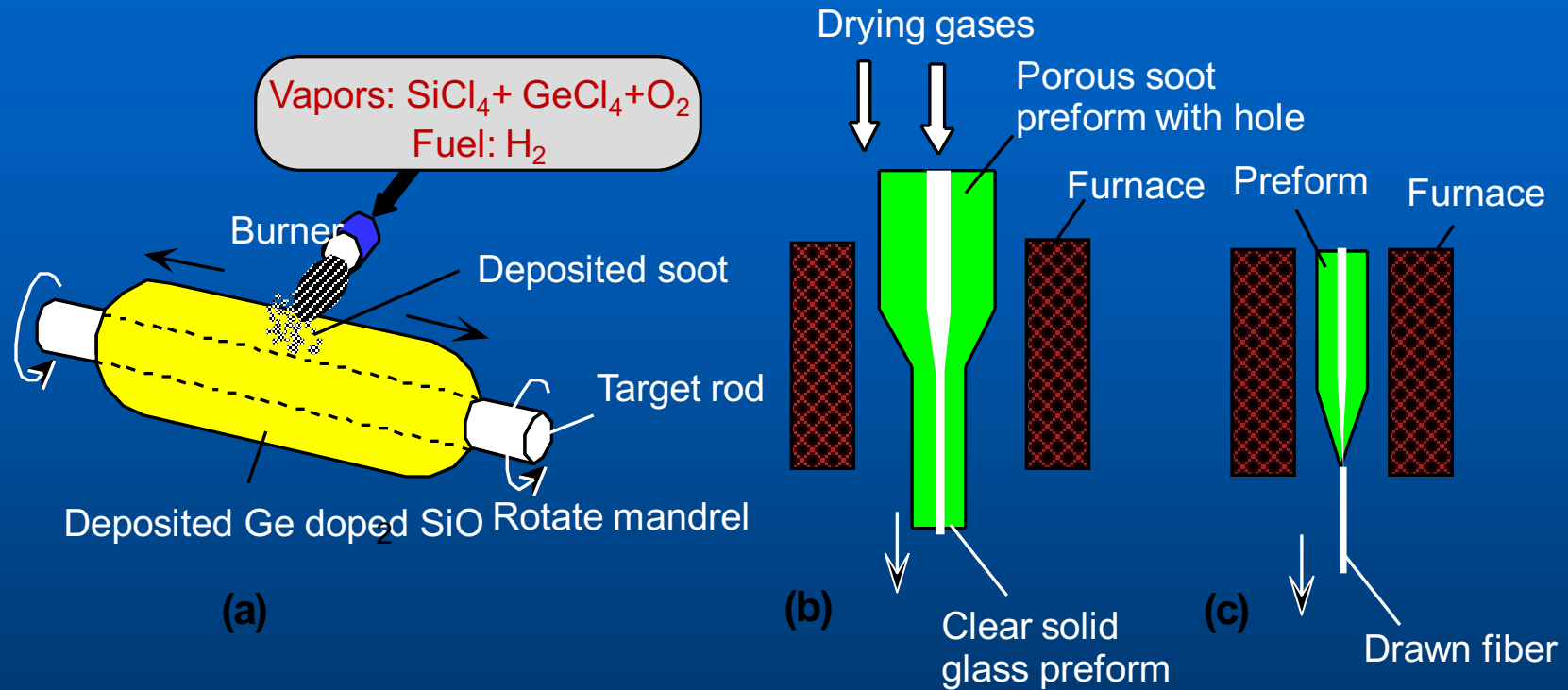

Outside Vapor Deposition Method used by Corning in 1970

© 1999 S.O. Kasap, *Optoelectronics* (Prentice Hall)



# Fiber drawing

- Many optical fiber production methods invented
  - OVD
  - VAD
  - MCVD
  - PCVD

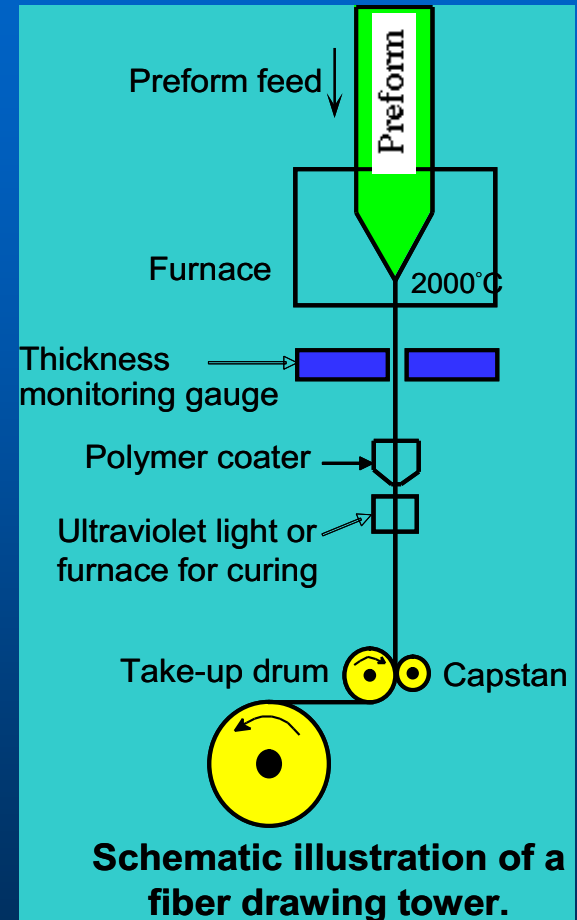

© 1999 S.O. Kasap, *Optoelectronics* (Prentice Hall)





# Light guiding inside fiber

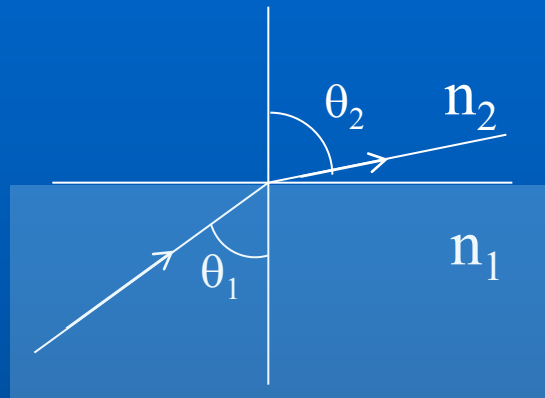

Snell's Law :  $n_1 \sin \theta_1 = n_2 \sin \theta_2$

Note: if we increase  $\theta_1$  to  $\theta_c$  such that  $\theta_2 = 90^\circ$

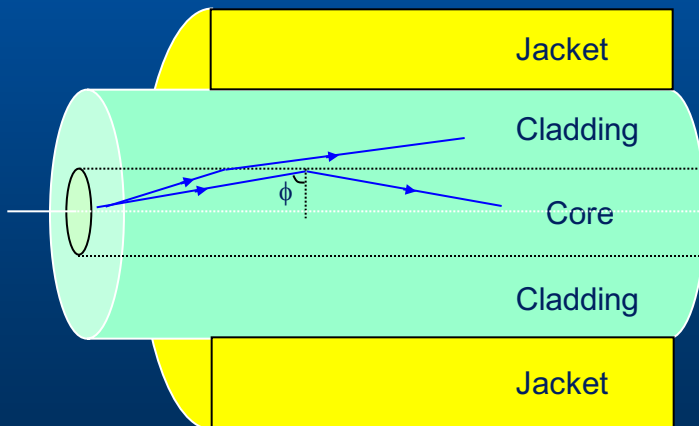

→

$$\sin \theta_c = \frac{n_2}{n_1}, \quad n_2 < n_1$$

If  $\theta_1 > \theta_c$

→

**Total Internal Reflection**



# High-capacity experimental demonstration

## 15.5 Terabits/sec capacity

- 155 wavelengths
- 100 Gbps each
- over 7000 km

A. H. Gnauck, et al.,  
"High-Capacity Optical  
Transmission Systems," *J.  
Lightwave Technol.* **26**,  
1032-1045 (2008)

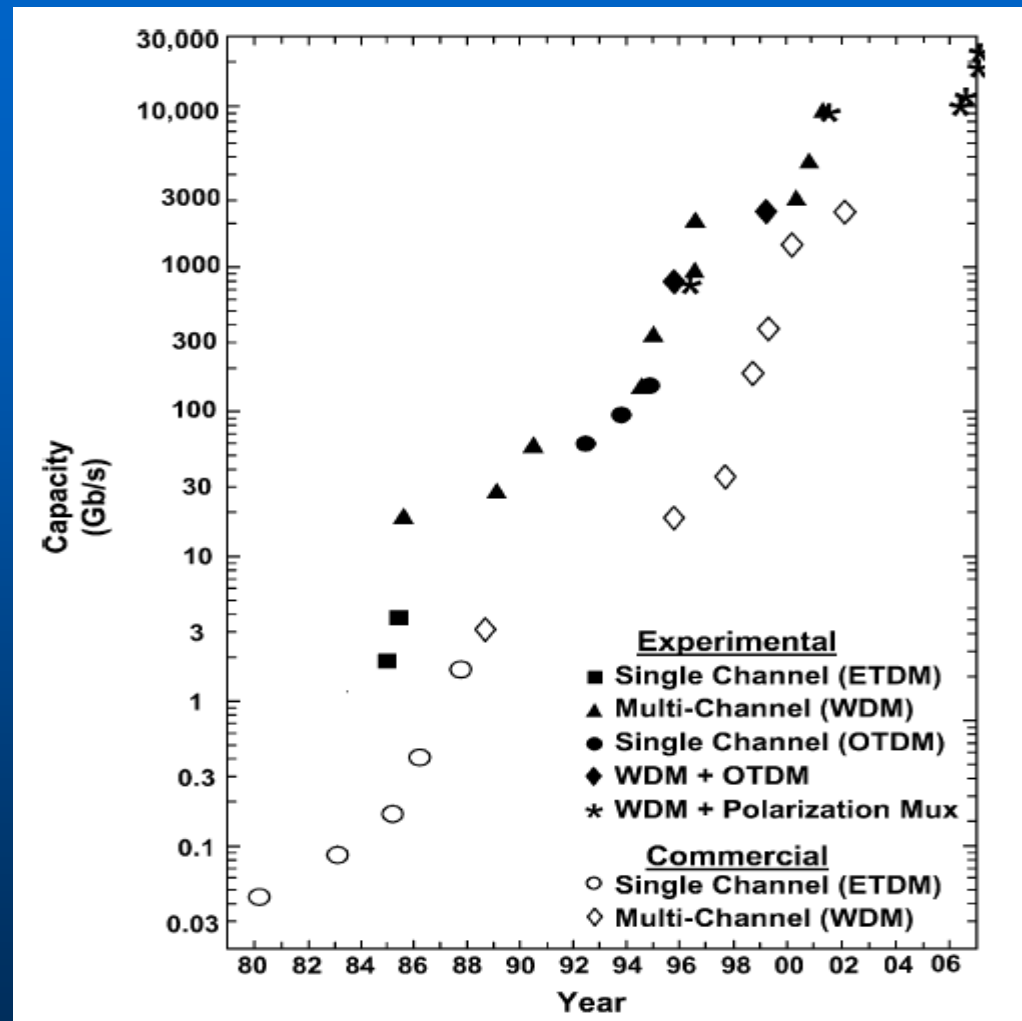

# Hundreds of millions of km of fiber cables deployed





# New industries created



# Submarine fiber optic systems

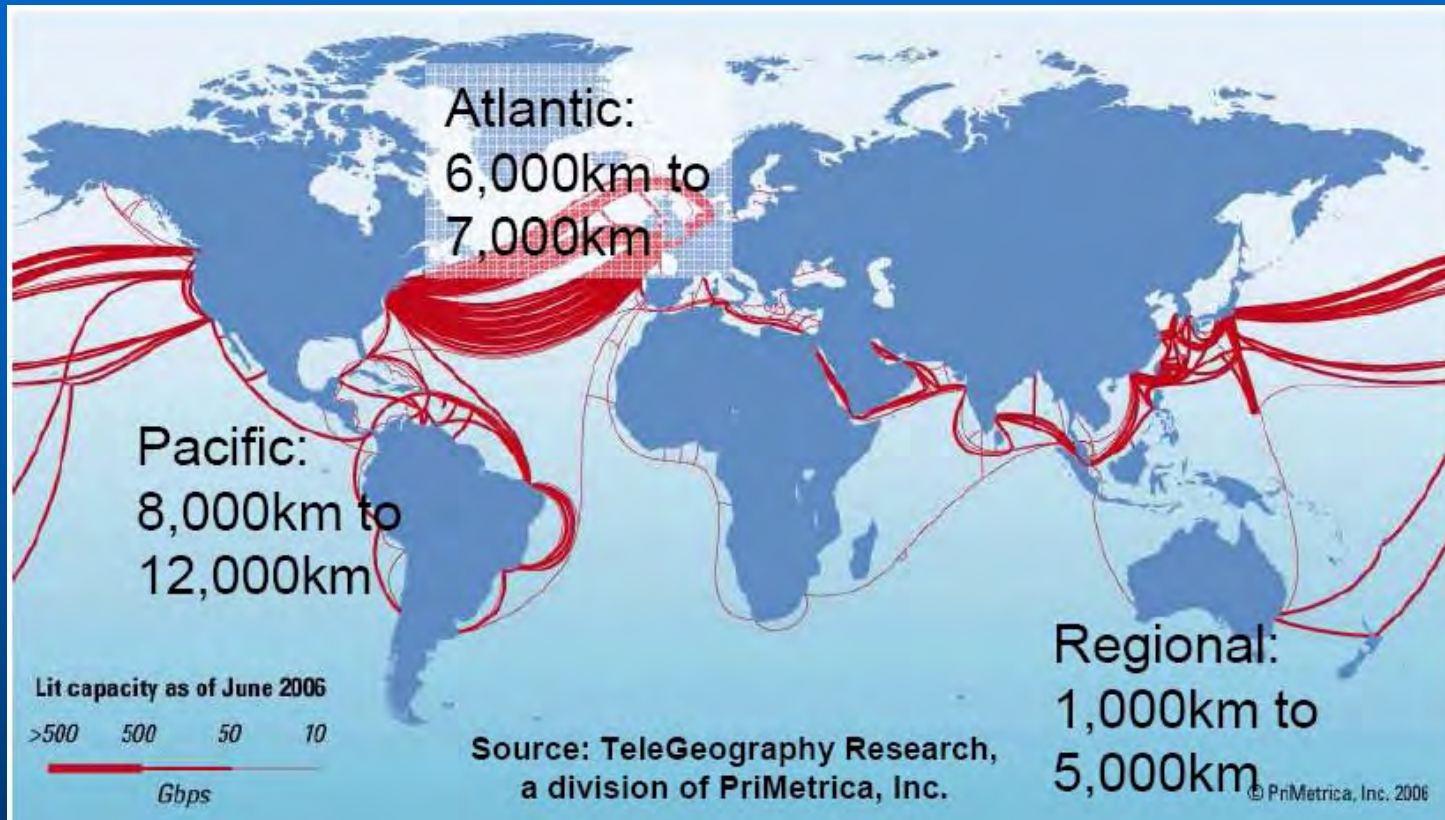

- Over 420,000 km of fiber in over 100 undersea fiber optic systems are deployed.

Courtesy: JX Cai, Tyco Telecommunications





# Global fiber deployment (million km)

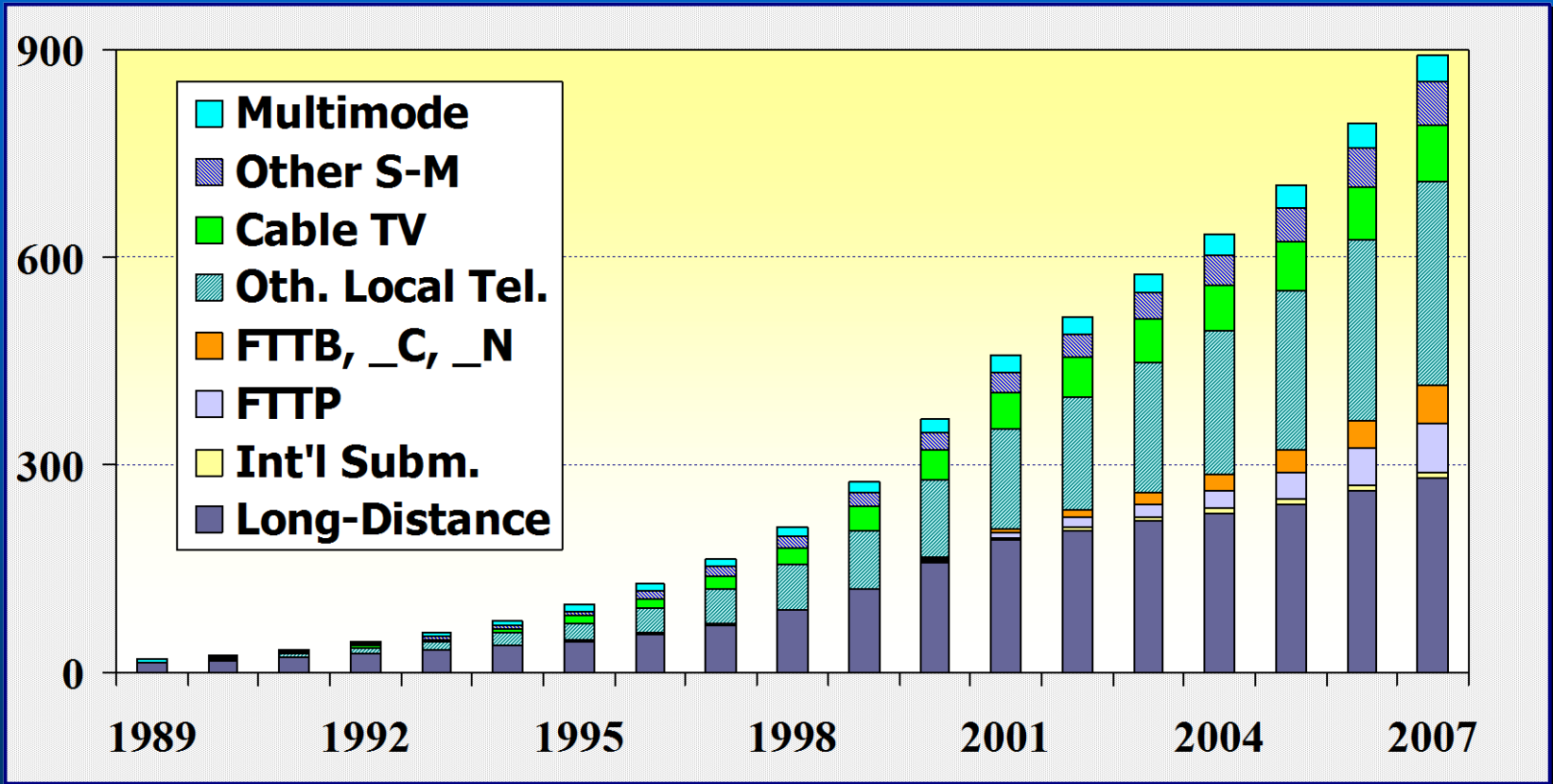

Other S-M = utility, railway, highway, government, military, premises, etc.  
Other local tel. =CO trunks, metro rings, business/office parks, CLEC, etc.

Source: KMI Research, CRU Group



# Telecomm service life cycle

Penetration

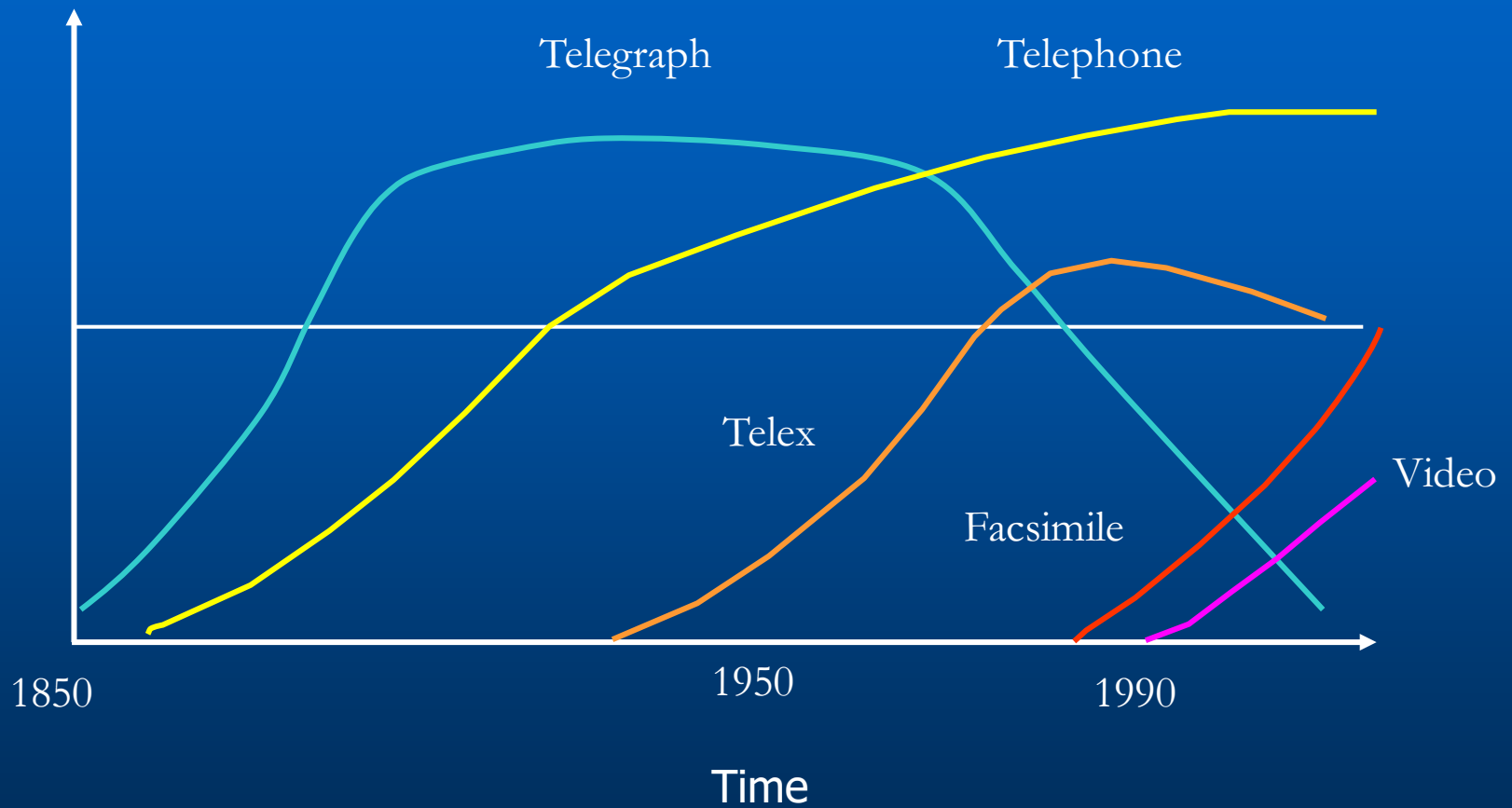

# When will fiber become obsolete?

- *"I cannot think of anything that can replace fiber optics."*
- *"In the next 1000 years, I can't think of a better system."*
- *"But don't believe what I say, because I didn't believe what experts said either."*



Courtesy of  
Radio Television  
Hong Kong





# Fiber around the globe



# Acknowledgement

The Chinese University of Hong Kong

- Prof Kenneth Young
- Prof Wing Wong
- Prof Kwok Cheung
- Prof Lian Chen

for their support in compiling this lecture

